

THIS IS NOT AN OFFICIAL DRAWING UNLESS MARKED WITH A CONTROL STAMP IN RED INK.
 NOTES: UNLESS OTHERWISE SPECIFIED

		REVISION			
LTR	ECO NO	DESCRIPTION	DATE	CHK	APVD
		NEW RELEASE	06-24-13		

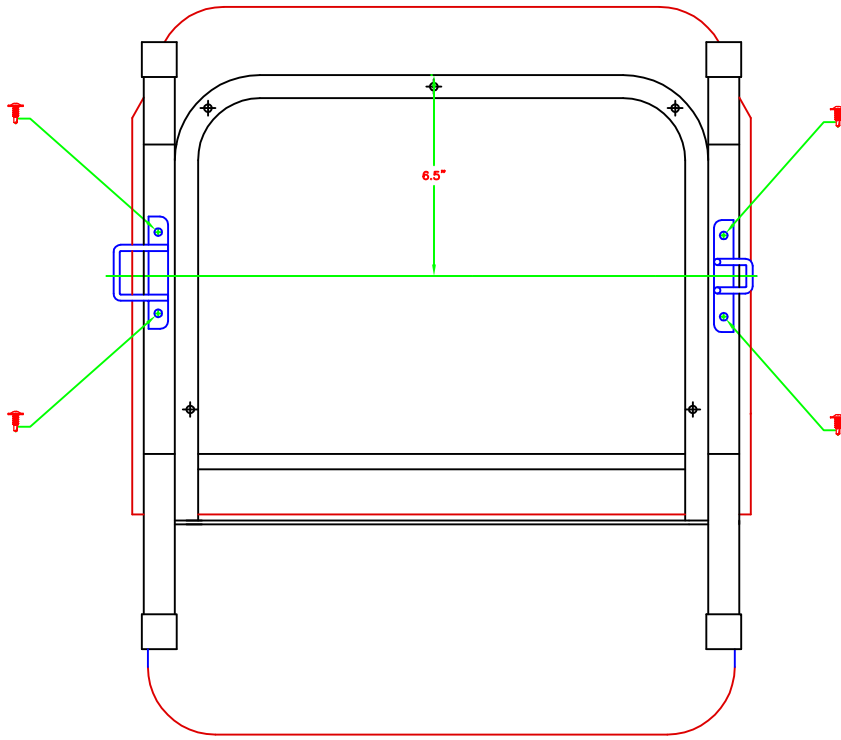

1. TURN THE CHAIR UPSIDE DOWN WITH THE BACK REST CLOSEST TO YOU.
2. USING A STRAIGHT EDGE, MEASURE 6.5" FROM THE TOP OF THE SEAT FRAME AND DRAW A MARK OVER THE LEG TUBE ON BOTH SIDES.
3. CENTER THE MALE GANGER ASSEMBLY ON THE RIGHT SIDE MARK AND ATTACH TO THE CHAIR FRAME USING THE SCREWS PROVIDED.
4. CENTER THE FEMALE GANGER ASSEMBLY ON THE LEFT SIDE MARK AND ATTACH TO THE CHAIR FRAME USING THE SCREWS PROVIDED.

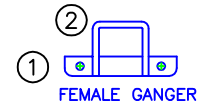
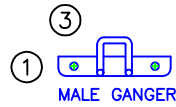

TOOLS REQUIRED:

- * DRILL
- * PHILLIPS DRIVER BIT
- * STRAIGHT EDGE
- * MARKER

ITEM	QTY	PART NO	DESCRIPTION
4	4	T11075	SCREW, 8-18 x 1/2", PH, MOD, TRUSS SDS, BLK OX
3	1	OP1800	PEW MALE GANGER
2	1	OP1600	PEW FEMALE GANGER
1	2	B00175	5/8" X 3 5/8", 2 HOLE GANGER BRACKET, 1/8" STEEL

<small>UNLESS OTHERWISE SPECIFIED DIMENSIONS ARE IN INCHES TOLERANCES: X FRACTION 1/4 X/X FRACTION 1/8 ANGLES ± 1/2° INTERPRET DWG PER DDD-5-1000 SURFACE FINISH: 125 BREAK SHARP EDGES TO .015 R. OR CHAMFER FILLETS: .015 R. MAX.</small>	DRAWN F. FLORES DESIGNER BERTOLINI APPROVAL 06-24-13	BERTOLINI INC. 13941 Norton Ave. Unit A Chino, CA 91710	
	MATERIAL		TITLE
	SEE PARTS LIST		6302F ADD ON INTERLOCKS INSTALLATION INSTRUCTIONS
	SCALE NONE		SIZE DWG NO D 6302F - INSTALLATION INSTRUCTIONS FILENAME 6302F - INSTALLATION INSTRUCTIONS SHEET 1 of 1

PROPRIETARY NOTICE
 THE DATA CONTAINED HEREIN CONSTITUTES PROPRIETARY INFORMATION OF BERTOLINI INC., AND SHALL NOT BE USED, DUPLICATED OR DISCLOSED IN WHOLE OR IN PART WITHOUT THE PRIOR WRITTEN CONSENT OF BERTOLINI INC.

REV. A